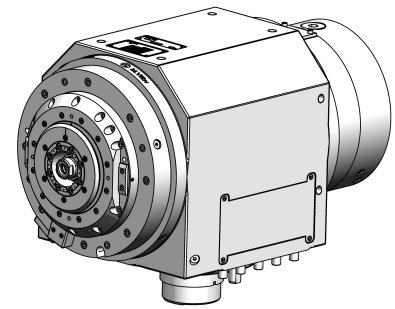

**milling spindle:
HSK-T63****12.000 min⁻¹****specification**

29.8.2023

interface:	HSK-T63
cleaning air:	2 channel
tool release unit:	WEISS/Hydr.
rotation unit:	GAT
encoder:	VS Sensorik
increment number:	300
max. speed:	12000 min ⁻¹
nominal speed:	3000 min ⁻¹
nominal power:	40 kW
nominal torque:	127,3 Nm
kind of motor:	asynchronous
moment of inertia (spindle):	0,0698 kgm ²
spindle housing design:	block
block size WxH:	275 mm
total length:	271,5 mm
working position:	tilting
front bearing:	
ISO Size Code:	10
bearing bore diameter:	70 mm
bearing pitch circle diameter:	90 mm
character speed value:	1,08 Mio dn
rear bearing:	
ISO Size Code:	10
bearing bore diameter:	70 mm
Arrangement of bearings:	<< M ~>>
bearing Lubrication:	grease

WEISS
G M B H