

WEISS

G M B H

WEISS  
G M B H  
A Siemens Company

WEISS Spindeltechnologie GmbH – A Siemens Company

# SWSS – SIEMENS WEISS SPINDLE SERVICE

Stand: September 1st 2023

Autor: SWSS



## SWSS – SIEMENS WEISS SPINDLE SERVICE

- **SWSS** is the abbreviation for „Siemens WEISS Spindle Service“
- **SWSS** is a network, consisting of
  - The head office in Maroldsweisach as a technical and organizational central
  - Global partners, acting as entrepreneur according to WEISS standards



# SWSS – SIEMENS WEISS SPINDLE SERVICE

- Our worldwide **SWSS** network

Our offices and partners are strategically spread across various locations worldwide. Each of them represents a hub for innovative ideas, collaboration and superior service.

You can find more information about our branches and partners on our website:

[Worldwide spindle service](#)



# SWSS – SIEMENS WEISS SPINDLE SERVICE

- Our SWSS team

A dedicated team of knowledgeable professionals is at your disposal to ensure your concerns and needs are met.

Your challenge is what drives us - your personal contacts will be happy to help you find an individual solution.

We cordially invite you to find out more about the contact details of your contact person on our homepage:

[Contact person at Weiss GmbH](#)



# SWSS – SIEMENS WEISS SPINDLE SERVICE

## ■ What does **SWSS** offer?

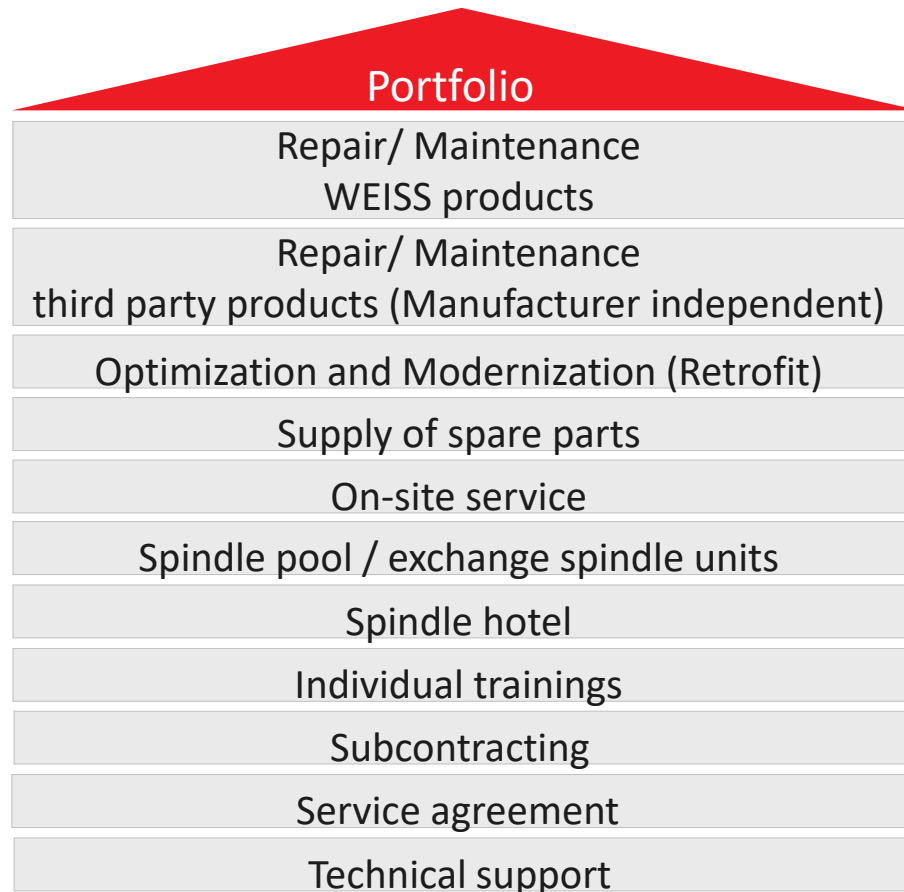

Needs-optimized combination of modules with the objective:

- Increasing machine availability

Our claim:

- needs-based / individually
- qualified
- rapid
- global
- inexpensive / price-optimized

More information can be found at:  
[Service-Portfolio](#)



# SWSS – SIEMENS WEISS SPINDLE SERVICE

- Portfolio: Repair and maintenance
  - of WEISS produced spindle units
    - with standardized processes for maximum technical and economical benefit
    - [Weblink - Maintenance and repair of WEISS spindle units](#)
  - of spindle units from further producers (Manufacturer-independent repair)
    - Design analysis and comparison with WEISS construction principles/construction know-how
    - Interpretation of technical alternatives – optimization
    - Consulting, offer and coordination with the customer
    - Production/repair using the WEISS standard processes
    - Warranty conditions analogous to Weiss spindle units
    - [Weblink - Maintenance and repair for spindle units form other manufacturers](#)

**ONE partner for all spindle repairs**

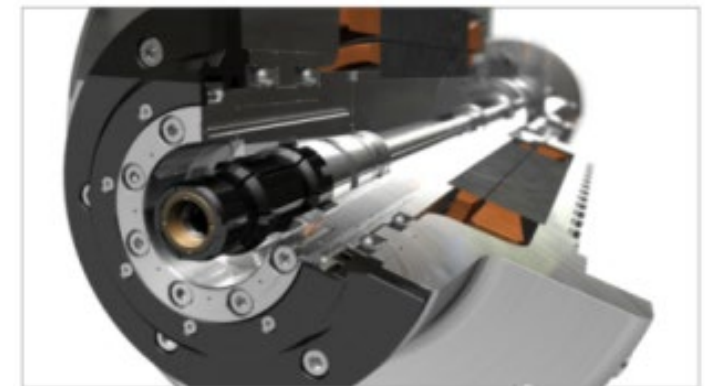

## SWSS – SIEMENS WEISS SPINDLE SERVICE

- Portfolio: Optimization / Modernization of WEISS produced spindle units and spindle units from further producers
  - Make up general product enhancements towards original design
  - Optimization based on findings from failure analyses
  - Optimization based on specific process requirements of end user
  - Checking the spindle design for compliance with engineering design principles
  - Analysis of customer needs / adaptation of the layout to the usage profile
  - Advice, development, offer and coordination for optimization
  - [Weblink - Retrofit](#)

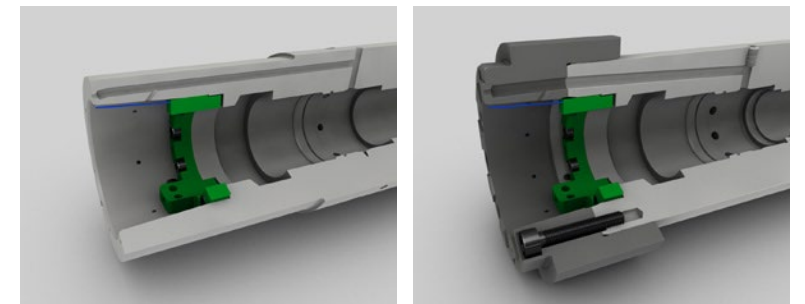

# SWSS – SIEMENS WEISS SPINDLE SERVICE

## ■ Portfolio: Supply of spare parts

- Stocking and sale of standard spare parts such as B. roller bearings
- Safety stock management with suitable replacement logistics
- Stocking of specific parts
  - Individually according to service agreement
  - Also for spindle units from other manufacturers
- Use of OEM components / original equipment manufacturer quality, application-specific upgrades if necessary
- [Weblink - Spare parts](#)

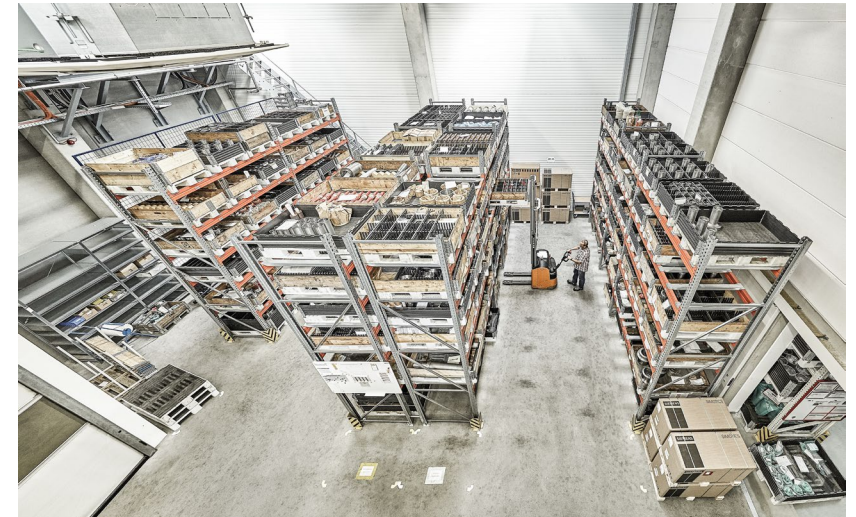



# SWSS – SIEMENS WEISS SPINDLE SERVICE

- Portfolio: On site service
  - Commissioning of a spindle unit in a machine in cooperation with the user's staff or, if necessary, with the machine tool manufacturer
  - Carrying out error diagnostics and fault clearance on main spindle units
  - Determination of the rolling bearing condition of a main spindle unit in the machine
  - Determination of the dynamic behavior of a main spindle unit in the machine
  - Dynamic balancing of drives, rotating systems and spindle units
  - Remote Services - we also support you remotely
  - [Weblink - On-site service](#)



# SWSS – SIEMENS WEISS SPINDLE SERVICE

## ■ Portfolio: Service-Spindle Pool

Ready-to-use replacement from the spindle pool– WEISS ensures professional storage and short-term delivery

### Why a Spindle Pool?

To keep costly downtime of tooling machines low, it is important to stock various spare parts. This is especially important with highly complex components like motorized spindles.

- Vibrations at the storage location, inadequate care, and non-movement of the rolling elements can lead to damage or corrosion.
- Long storage times can result in the loss of critical functional properties, and operational readiness can longer be guaranteed.
- If bearing grease is not moved, it loses its oil permeability which can result in uneven distribution (friction) and premature wear.

### 1. Proper Storage

### 2. Appropriate Grease Distribution Run

### 3. Regular Test Runs

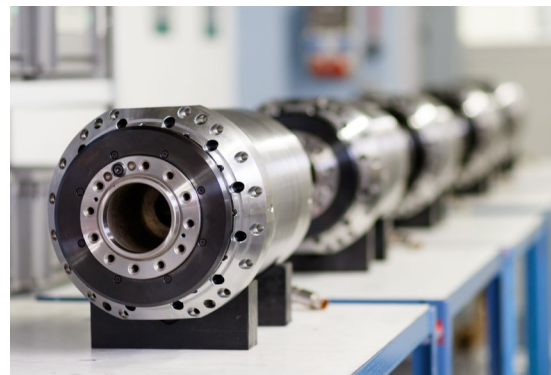

### Our Promise

- Professional Storage
- Short-term Availability

### Our Exchange Concepts

- Exchange Customer
- Exchange Weiss
- Spilt Repair

- [Weblink - Spindle pool](#)

# SWSS – SIEMENS WEISS SPINDLE SERVICE

- Portfolio: Customer training
  - Effective training is not only economical for the operator, the assembly and maintenance staff, but ultimately for your entire company
  - Learn how to use spindle systems correctly
  - Carry out maintenance work independently
  - Carry out small repairs independently
  - Find out more about the individual options on our website:
  - [Weblink - Training](#)



# SWSS – SIEMENS WEISS SPINDLE SERVICE

## ■ Portfolio: Subcontracting

We would be happy to carry out the following high-quality contract work on your behalf:

- High-precision grinding of various components
- Balancing rotating parts
- laser markings
- laser cladding

We cordially invite you to find out more about the various options on our homepage:

[Weblink - Subcontracting](#)

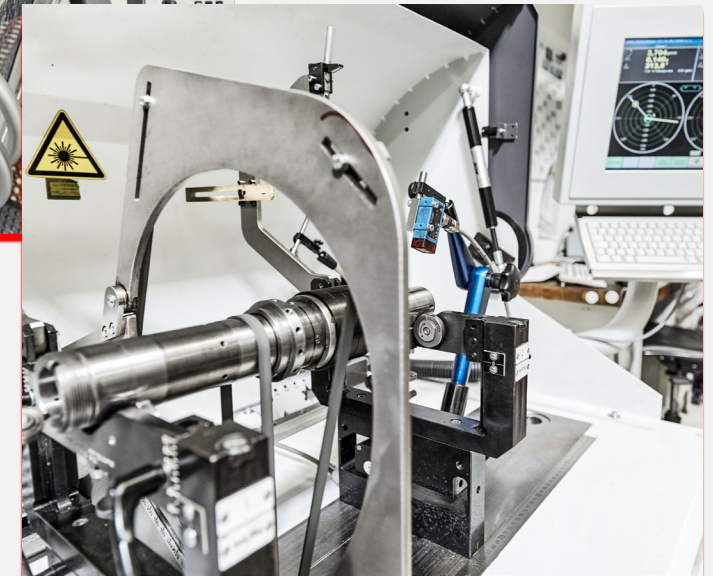

# SWSS – SIEMENS WEISS SPINDLE SERVICE

## ■ Portfolio: Service Agreements

- An individual service agreement guarantees you high machine availability
- Your personal account manager will work with you to develop a concept for the maximum availability of spare parts and replacement spindle units
- Find out more about the individual options on our website:
- [Weblink - Agreements](#)

# SWSS – SIEMENS WEISS SPINDLE SERVICE

## ■ Portfolio: Technical Support

### ■ Contact

- Hotline: +49-9532-9229-347
- Fax: +49-9532-9229-377
- E-Mail: [service@weissgmbh.de](mailto:service@weissgmbh.de)

### ■ Availability

- Office hours Monday to Friday 07:00 – 17:00 CET
- Extended availability outside office hours under the same number until 10 p.m
- Extended availability also on Saturdays until 2 p.m



# SWSS – SIEMENS WEISS SPINDLE SERVICE

## ■ Repair process



1-Incoming inspection



2-Disassembly



3-Analysis



4-Report



5-Coordination/ Offer



6-Spare parts



7-Machining



8-Quality check



9-Balancing shaft



10-Mechanical Assembly



11-Assembly Adjustment



12-Final Assembly



13-Grinding Tool



14-Grease repl.



15-Final inspection



16-Versand

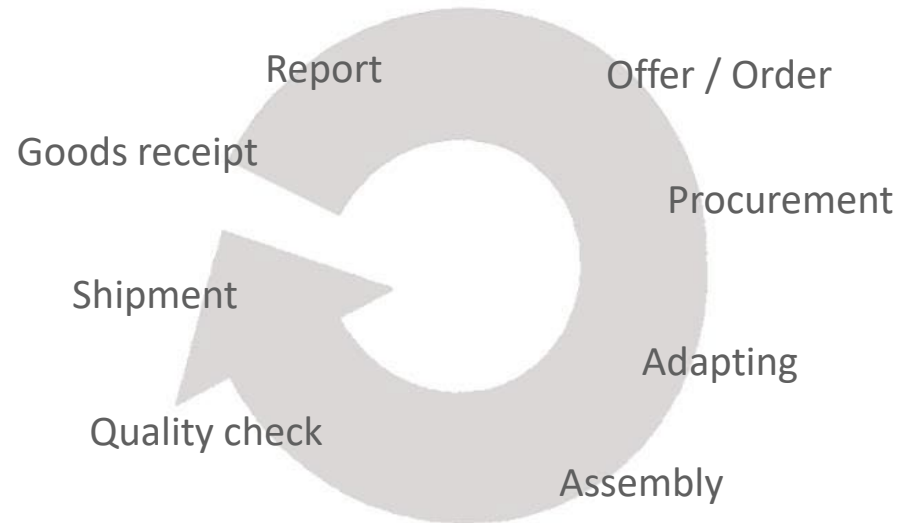

# SWSS – SIEMENS WEISS SPINDLE SERVICE

- Parts replaced by standard during wear-and-tear repair

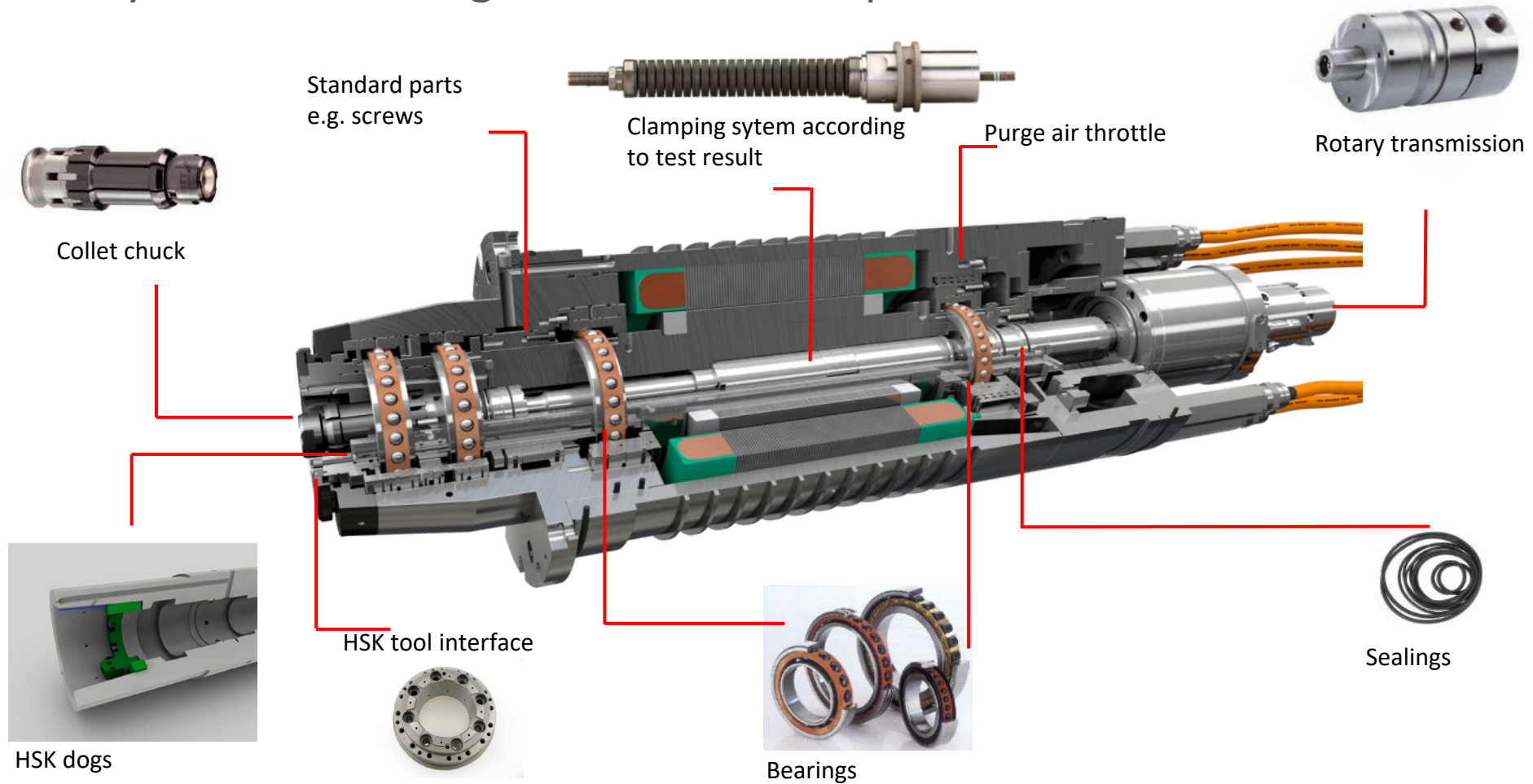



# SWSS – SIEMENS WEISS SPINDLE SERVICE

## ■ Parts replaced according to test result

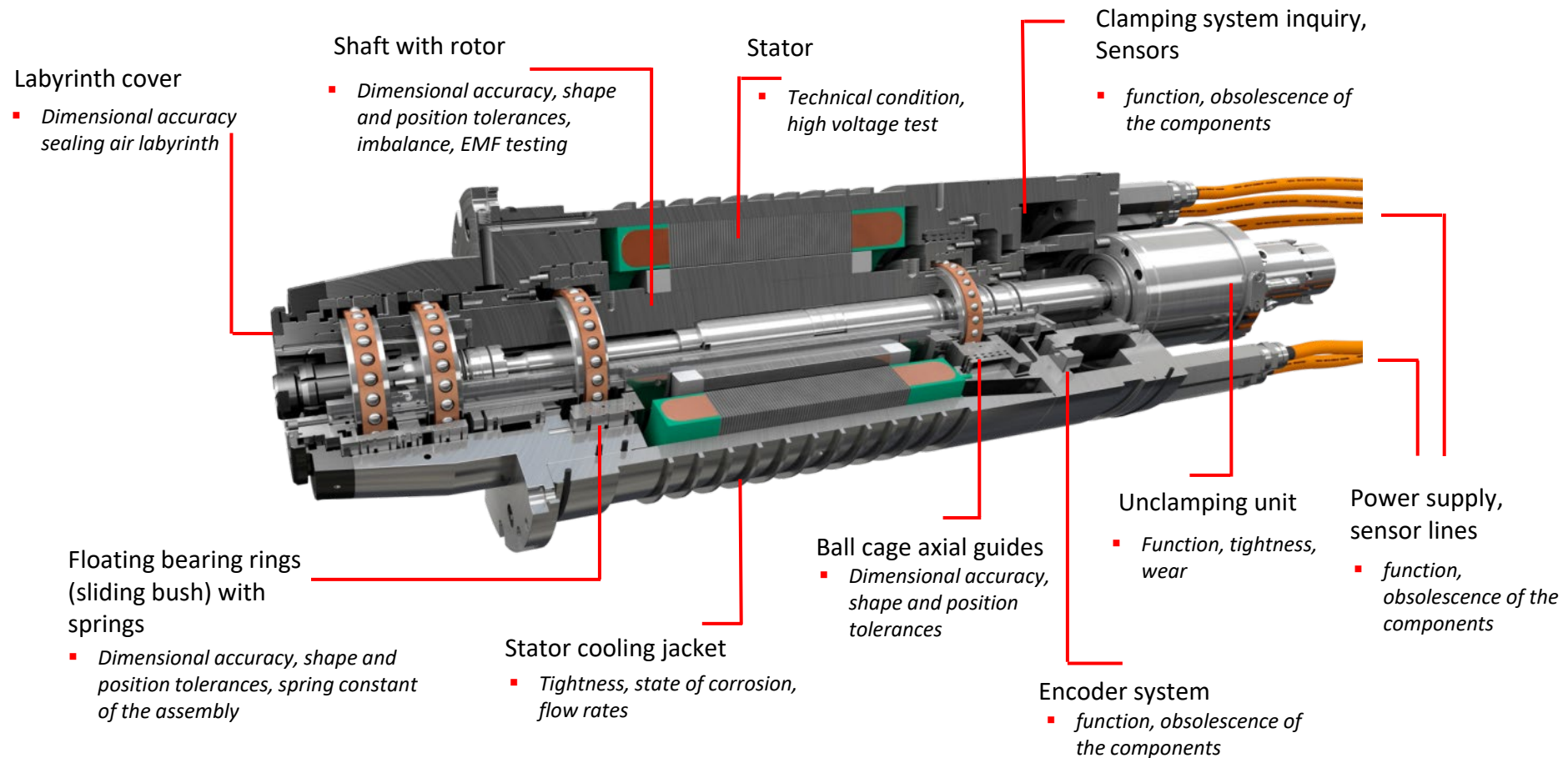

# SWSS – SIEMENS WEISS SPINDLE SERVICE

## Excerpt of relevant tests during repairs at WEISS

Component properties may have changed during use or in the event of damage. The components that are reworked or replaced can be found in our detailed analysis report

On our modern test stands, each repaired spindle unit undergoes the same automated test run as a new spindle. Extensive data is recorded to ensure that the mechanical, electrical and thermal properties are in order and that the acceptance criteria agreed with the customer are met

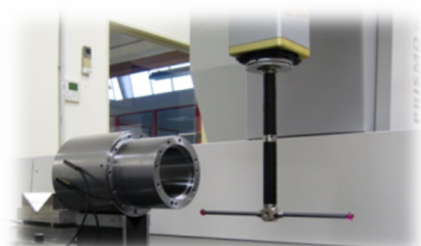

Measurement of dimensional accuracy, form and position

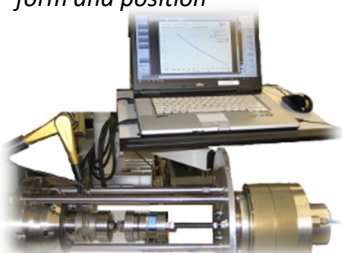

Checking the bearing preload

**Spindelanalyse** WEISS

**Projekt-Nr.:** 99903671 G M B H  
**Produkt-Nr.:** 94920449-9425  
**Bezeichnung:** Step 1 Tec 6042.8203

<b>Auftraggeber</b>	Max Mustermann GmbH	Kunden-Nr.	999999
PLZ / Ort	Musterstadt	Bestell-Nr.	888888
Anspruchspartner	Herr Mustermann	Lieferschein-Nr.	123456
Telefon	09532-9229-308	Fax	09532-9229-444

<b>ODM</b>	Maschinen Musterbau AG	Kunden-Nr.	888888
Name	Musterstadt	Bestell-Nr.	444444
PLZ / Ort	Musterstadt	Lieferschein-Nr.	14789
Anspruchspartner	Frau Mustermann	Fax	09532-9229-444
Telefon	09532-9229-308		

<b>Endanwender</b>	Max Mustermann GmbH	Kunden-Nr.	999999
Name	Musterstadt	Bestell-Nr.	888888
PLZ / Ort	Musterstadt	Lieferschein-Nr.	123456
Anspruchspartner	Herr Mustermann	Fax	09532-9229-444
Telefon	09532-9229-308		

**Rücksendegrund**  
laut Lieferschein  
Erschuss

Maschinennummer:	545XYZ-445	Erstellung:	02.2005
Einbaudatum:	05.07.2007	Letzte Auslieferung:	02.2007
Ausbaudatum:	01.07.2010	Anlieferung:	19.07.2010

**Eingangsprüfung / Befundung**

		
Vorne	Mitte	Hinten

Rücksendegrund	bestätigt	Spindelwelle	rauer Lauf
Allgemeinzustand	verschlissen/verschmutzt	Laufzeit (h)	9500
Kollisionsmerkmal	nein		
Gewährleistung	außerhalb der Sachmängelhaftung		
Fehlerliste	keine		

Reaktion 0903671/2 Seite 1 von 9

WEISS analysis report

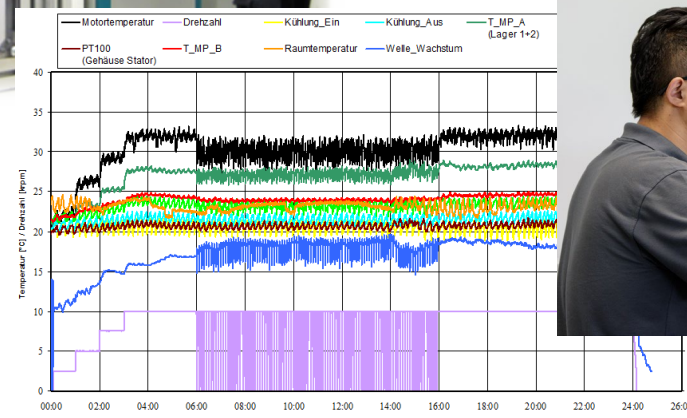
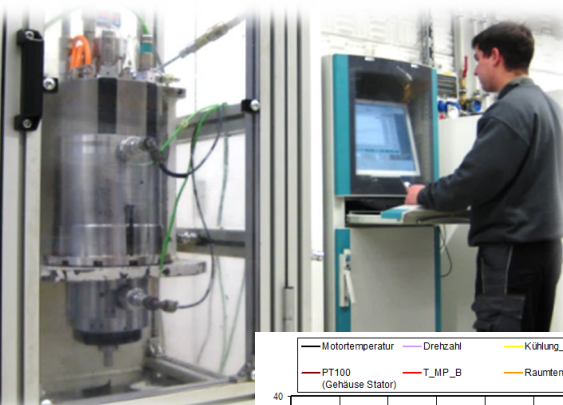

Records from the test run



# SWSS – SIEMENS WEISS SPINDLE SERVICE

- When to call **SWSS** contact partner?
  - A wear-and-tear repair announces?
    - Quality problems, machine behavior is changing...
  - Machine is out of warranty period?
    - During warranty period for machine problems always get in contact with the supplier.
  - Spindle run duration below technical opportunity?
    - During maintenance, WEISS can check spindle design and provide proposals how to do some optimisation.
  - Are there spare parts/spare spindles available?
    - The availability of spare parts was not agreed for all spindle types.
  - You need on-site support?
    - The spindle unit does not always have to be removed for maintenance/repair.
  - To compare price and performance, you need an alternative offer?
    - Comparing the prices seems easy, but whether it is a question of a high-quality service is only shown by the operating time that can be achieved